

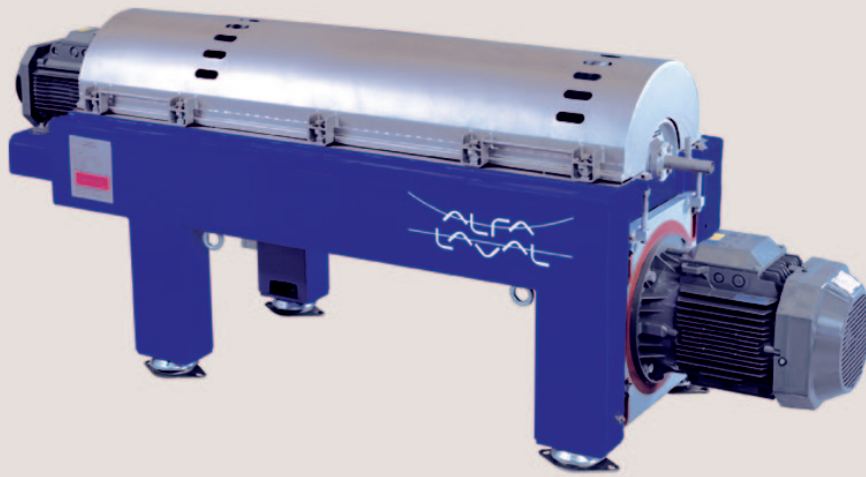

ALDEC

High-performance decanter centrifuge



Applications

The ALDEC range of decanter centrifuges was developed with a focus on cost-efficiency, reliability and easy operation. The ALDEC design is used for sludge dewatering in a wide range of industrial wastewater treatment applications, as well as municipal wastewater treatment plants.

Ideal for both small and medium-capacity installations

ALDEC decanter centrifuges are designed to be efficient, simple to install, easy to maintain and straightforward to operate. Installation, operating and service life costs are minimal.

The ALDEC range features

- fully enclosed process sections
- critical parts made of wear-resistant material
- high performance combined with low energy consumption.

Benefits

The ALDEC decanter centrifuge design provides a series of concrete benefits

- reduces sludge volume, which cuts down on transport and disposal costs

- continuous operation
- compact, modular design saves space
- low installed power reduces electricity consumption.

Working principle

Separation takes place in a horizontal cylindrical bowl equipped with a screw conveyor (see drawing on page two). The feed enters the bowl through a stationary inlet tube and is accelerated smoothly by an inlet distributor. The centrifugal force that results from the rotation then causes sedimentation of the solids on the wall of the bowl.

The conveyor rotates in the same direction as the bowl, but slightly slower, thus moving the solids towards the conical end of the bowl. The cake leaves the bowl through the solids discharge openings into the casing. Separation takes place throughout the entire length of the cylindrical part of the bowl, and the clarified liquid leaves the bowl by flowing over adjustable plate dams into the casing.

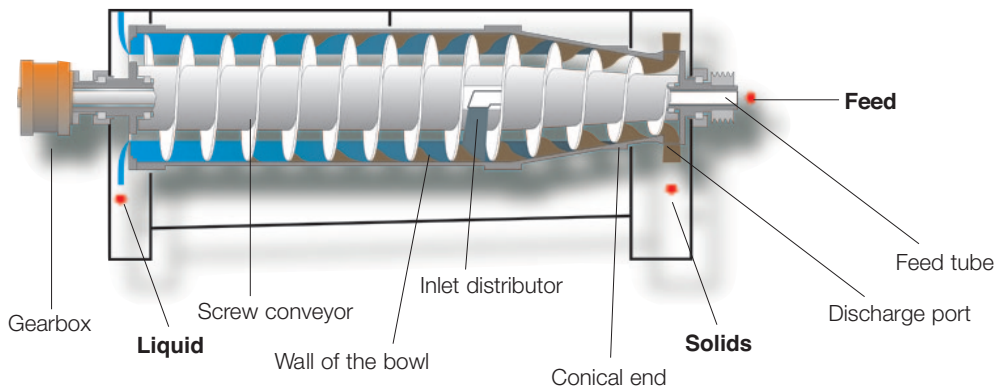

Process optimization

ALDEC decenter centrifuges can be adjusted to suit specific requirements by varying

- the bowl speed to obtain the G-force required for the most efficient separation
- the conveying speed for the most efficient balance between liquid clarity and solids dryness
- the pond depth in the bowl for the most efficient balance between liquid clarity and solids dryness
- the feed rate – ALDEC decenter centrifuges are designed to handle a wide range of different flow rates.

Design

The rotating part of these decenter centrifuges is mounted on a compact, in-line frame, with main bearings at both ends. Vibration dampers are placed under the frame. The rotating part is enclosed in a casing with a cover and a bottom section with integrated outlets for both solids and the liquid being removed.

Drive system

In all ALDEC decenter centrifuges, the bowl is driven by an electric motor and a V-belt transmission drive. Power is transferred to the conveyor via a planetary gearbox.

Operation can either be pre-set to a suitable set of parameters, or the difference between the speeds of the bowl and the conveyor can be controlled automatically, with no need for changing belts or pulleys.

Materials

The bowl, conveyor, inlet tube, outlets, cover and other parts in direct contact with process media are all made of stainless steel. The discharge ports, conveyor flights and feed zone are protected with materials that are highly resistant to erosion. The frame is made of mild steel with an epoxy enamel finish.



The Basic Core Controller

Each decenter centrifuge in the ALDEC range equipped with a variable frequency drive (VFD) as standard is delivered with the Basic Core Controller (BCC). This control package is capable of fully controlling the decenter operation, ensuring the most efficient performance and keeping costs for installation, commissioning, operation and maintenance to a minimum. The controller is also designed to measure the temperature of the bearings, and to monitor vibration levels.



Dimensions

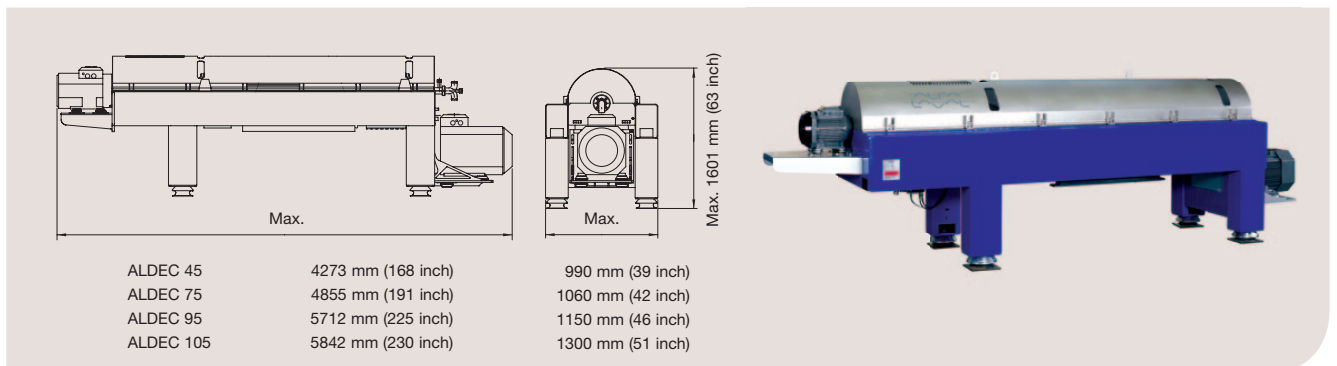
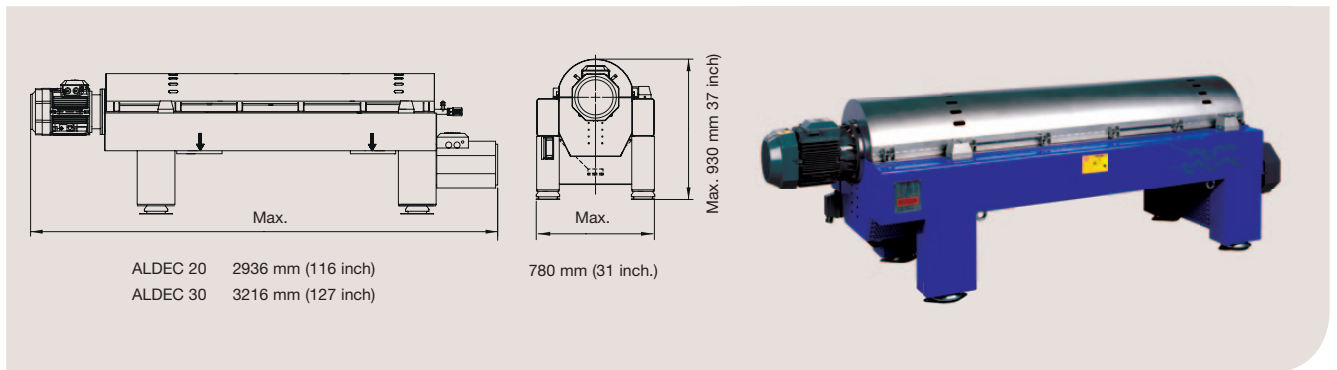
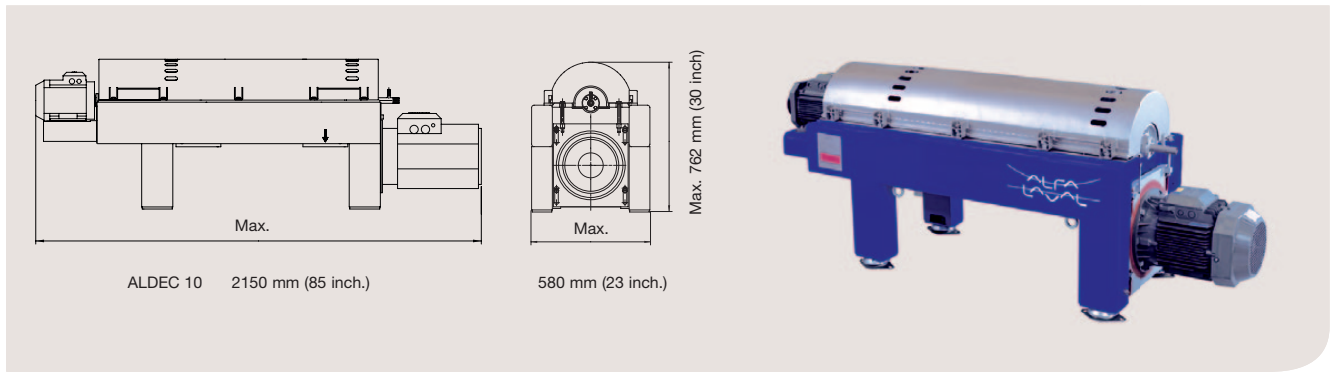

Technical Data

Designation	Max. weight kg (lbs)	Bowl material	Material for other parts in contact with sludge	Typical main drive size kW (HP)	Typical back drive* kW (HP)	Start method
ALDEC 10	375 kg (830 lbs)	AISI 316	AISI 316	7.5 kW (10 HP)	3 kW (4 HP)	Star-delta, VFD
ALDEC 20	1125 kg (2495 lbs)	AISI 316	AISI 316	11 kW (15 HP)	7.5 kW (10 HP)	Star-delta, VFD
ALDEC 30	1200 kg (2660 lbs)	AISI 316	AISI 316	11 kW (15 HP)	7.5 kW (10 HP)	Star-delta, VFD
ALDEC 45	2300 kg (5071 lbs)	AISI 316	AISI 316	22 kW (30 HP)	5.5 kW (7 HP)	Star-delta, VFD
ALDEC 75	3200 kg (7050 lbs)	DUPLEX	AISI 316	37 kW (50 HP)	11 kW (15 HP)	Star-delta, VFD
ALDEC 95	4500 kg (9000 lbs)	DUPLEX	AISI 316	55 kW (75 HP)	11 kW (15 HP)	VFD
ALDEC 105	5000 kg (11023 lbs)	DUPLEX	AISI 316	75 kW (100 HP)	22 kW (30 HP)	VFD

How to contact Alfa Laval

Up-to-date Alfa Laval contact details for all countries are always available on our website at www.alfalaval.com